



Return the device to a certified provider at the end of its useful life!

Not suitable for children under 14 years. This is not a toy.

Solar cyclist / e-biker

Wooden building kit with gearbox, runs on "solar fuel"

Not a toy!



Item no. 50040



ASSEMBLY INSTRUCTIONS

1 BUILDING THE GEARBOX, parts:

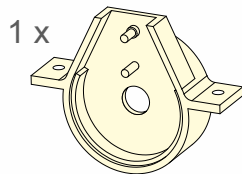
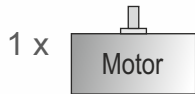

Gearbox casing

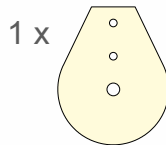

Gearbox cover

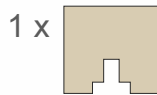

Spacing template



A Place the small gear on the table.

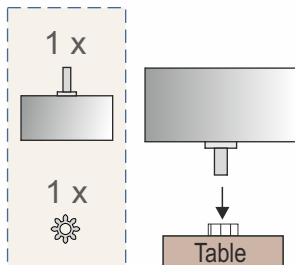

B Carefully slide the motor shaft into the small gear.

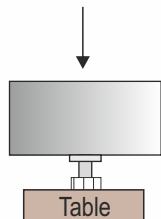

C Then use the spacing template to carefully push the small gear all the way down.

Apply spacing template...

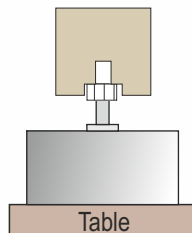

...push down

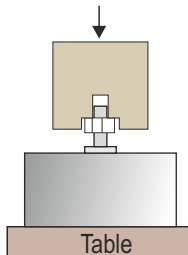

...all the way down
(Small gap remains between gear and motor)

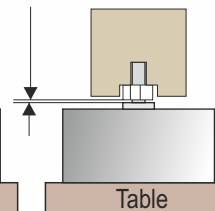

The gear is now correctly positioned on the 1 x motor shaft.

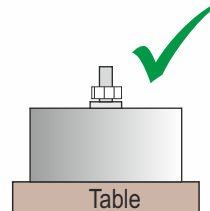

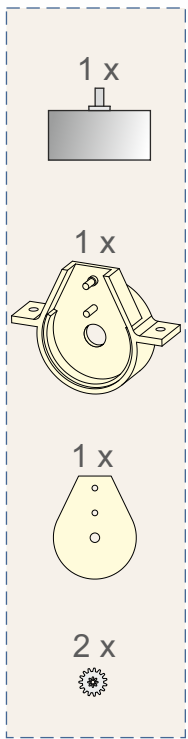

D Place the motor on the table with the motor cable toward you.



E Push the gearbox casing all the way over the motor, applying pressure. The pins are facing away from you.

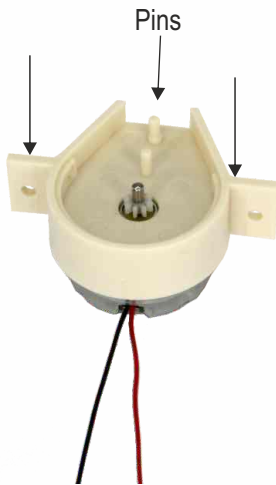

F Then one by one place the two twin gears on the pins.

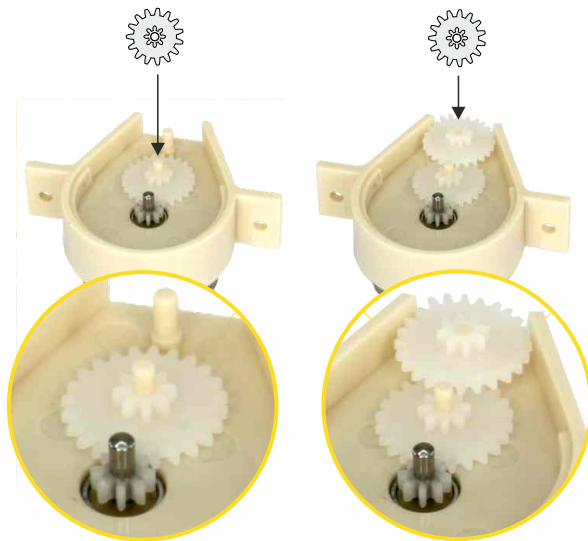

- G** Applying **light pressure**, push the cover into the gearbox casing until it is secured.

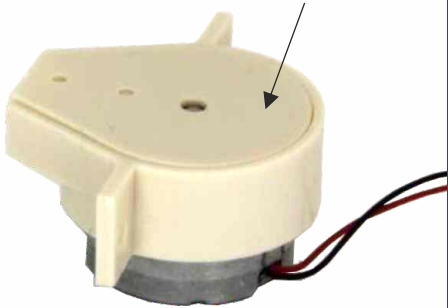

- H** Then carefully turn over the gearbox, place it on the table and firmly press on the strips. This closes the casing.

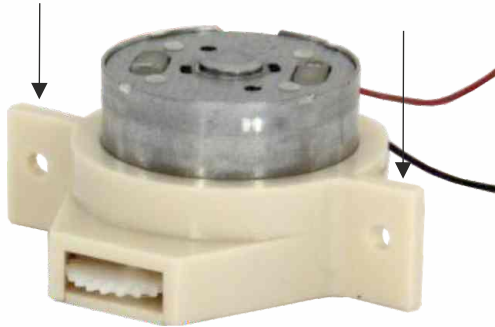

- I** If the gearbox is now easy to turn with your finger, you can move to the next page to continue assembly. If it doesn't turn, open the cover and look where the gear is block and correct the problem.

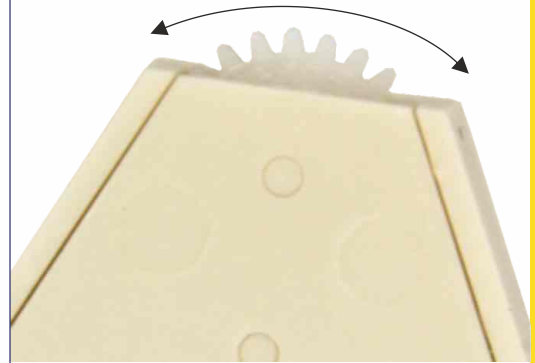

2 ATTACHING THE BASE

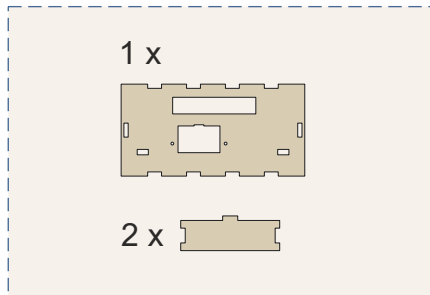

A Set the base in front of you in the correct direction:

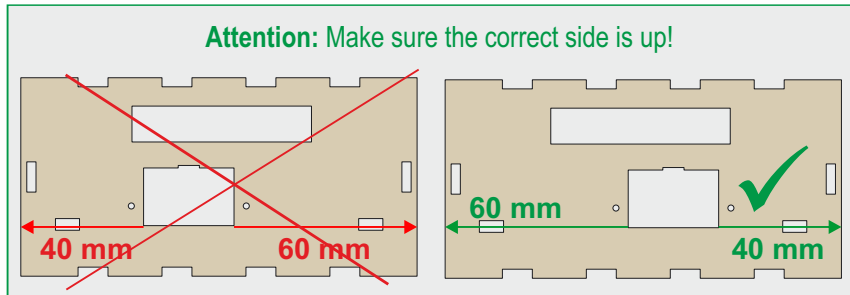

B Apply a little glue in the areas on the sides with the red mark:

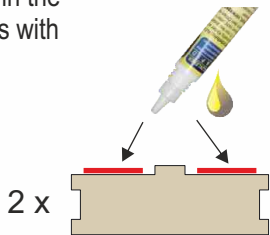

C Now attach the sides to the base:

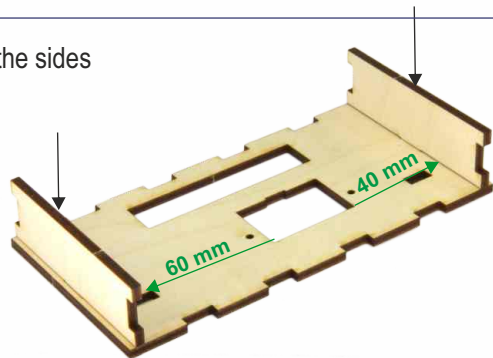

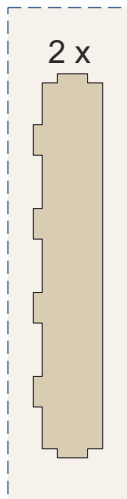

D



Apply a little glue in the six locations with the red mark.

E

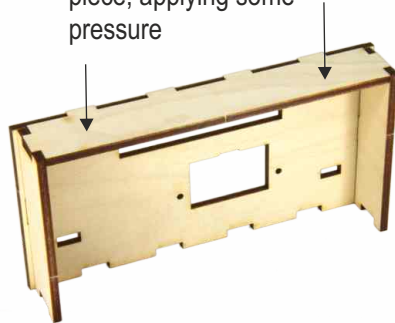

Attach the long wooden piece, applying some pressure

F



Apply a little glue in the six locations with the red mark.

G

Attach the long wooden piece, applying some pressure.

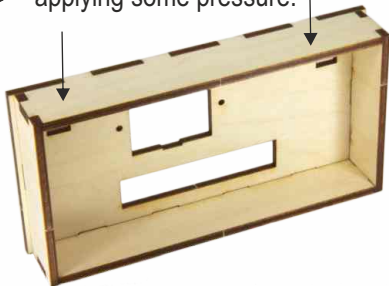

The base is now complete!

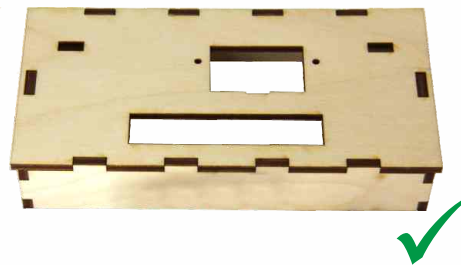

DECISIONS, DECISIONS... Attach the air pump or battery pack

After deciding if you want to install the battery or the air pump, apply a small dot of glue in the notches on the bike frame and attach your option flush with the bike frame, applying some pressure.

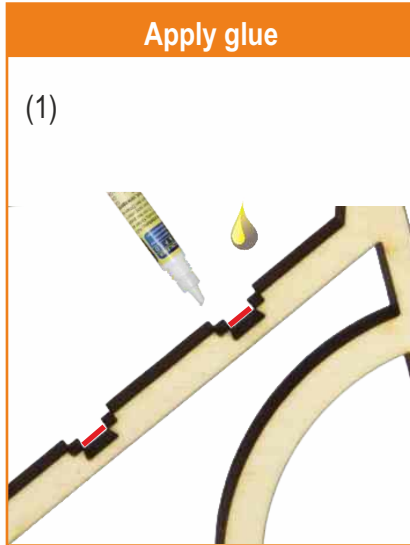
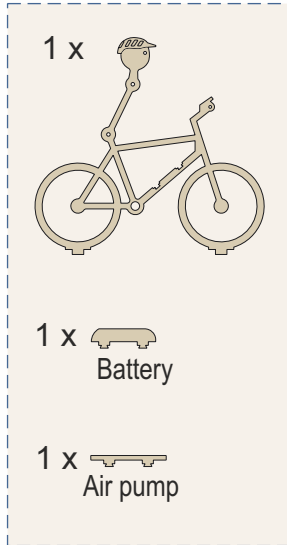

Either:



Or:

2 x 

2 x 

1 x



Gearbox unit

H

Insert the gearbox in the base, insert the 2 screws into the holes...

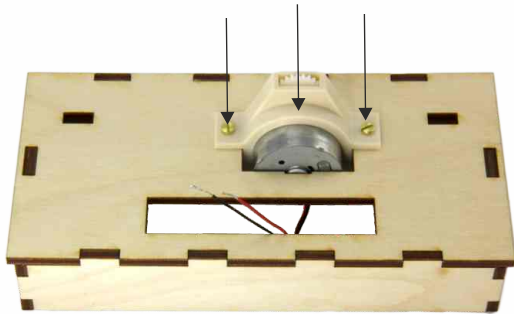

I

... and secure from the back with the nuts.

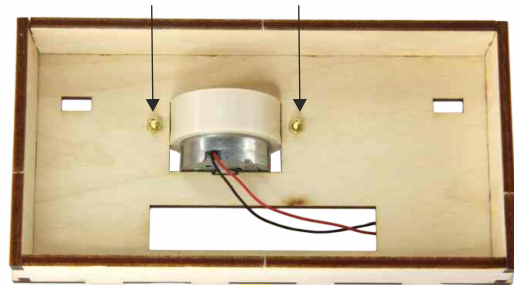

SPROCKET ASSEMBLY

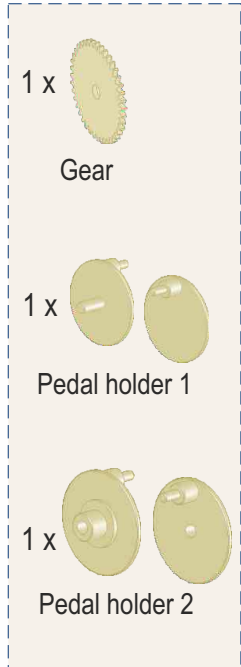

- (1) Slide **pedal holder 2** into the shaft opening on the cyclist.



- (2) Attach the gear to **pedal holder 1**, then slide this unit into **pedal holder 2**.



- (3) Important: Turn the two pedal holders so the pedals are 180° from each other!

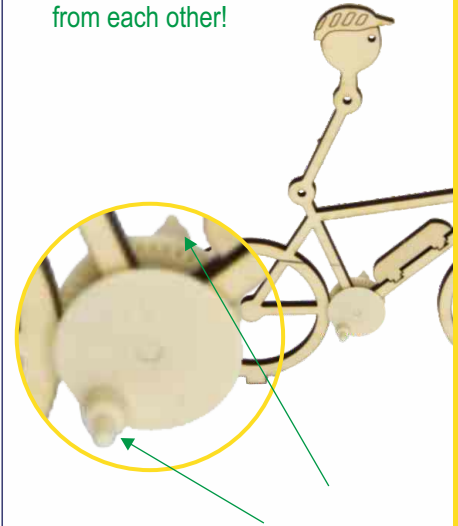

3 ATTACHING THE CYCLIST TO THE BASE

The cyclist is easiest to attach and align when the gearbox is turning. If you have enough light, you can use the solar cell. If you do not have enough light, use a standard 1.5 Volt battery to power the gearbox.

A Attaching the cyclist powered by solar cell



- (1) Install the solar cell as shown below.



- (2) Attach the motor cables to the terminals, inserting **the red cable into the ⊖ eye** and the **black cable into the ⊕ eye**.

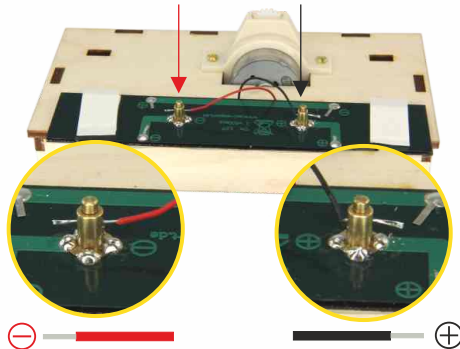

- (3) Now position the solar cell, but do not attach to the base with the adhesive pads yet.

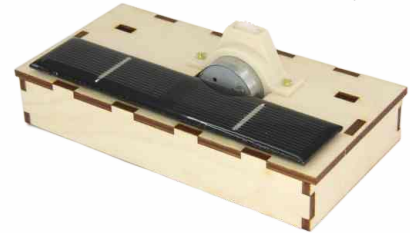

You can either use a very bright LED lamp (3 Watt or higher) or even better expose the solar cell to direct sunlight to power the gearbox. If the gearbox turns, you can start attaching the cyclist.

B Attaching the solar cyclist with light

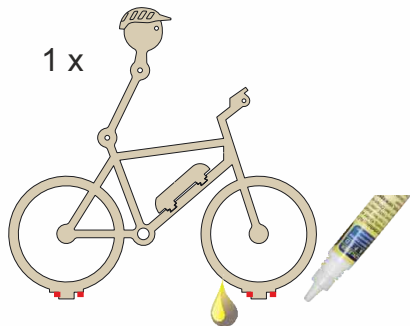

Apply glue to the areas with the marking, insert the cyclist in the base and align so the gears can easily engage with the gearbox turning and the cog in the cyclist can easily move along.

Allow the glue to dry approx. 10 minutes. Do not move the cyclist during this time. Then attach the adhesive pads on the solar cells to the base.

Shine a torch onto the middle of the solar cell:



Example:
Torch with 3 Watt LED

Carefully adjust the cyclist along the arrows until the model runs smoothly:



Example:
Desk lamp with 6 Watt LED

C Assembly with 1.5 Volt battery

Tape the end of the black cable to the **+ terminal** of the battery with adhesive tape or packing tape.



1 x  Alkaline
AA-LR6 - 1.5 V

Standard 1.5 Volt battery
(not included)



Tape the end of the red cable to the **- terminal** of the battery with adhesive tape or packing tape.

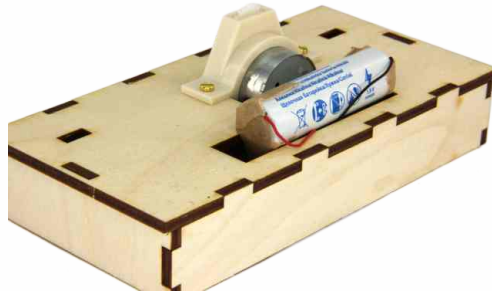
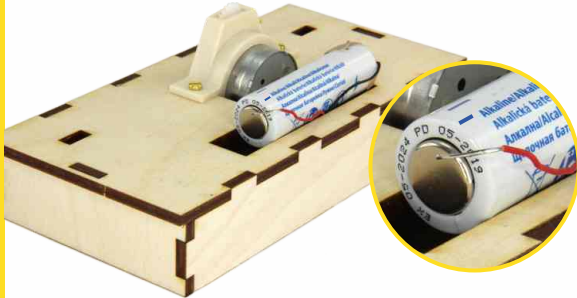

The gears must now turn:

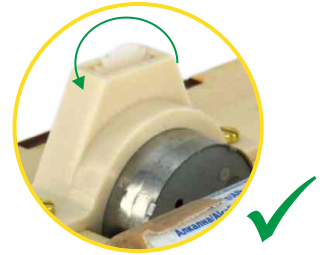

Attaching the cyclist with battery

(1)

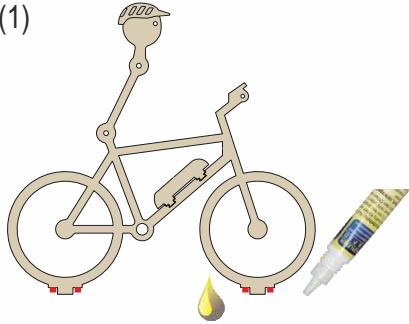

Apply glue to the areas with the marking, insert the cyclist in the base and align so the gears can easily engage and the cog in the cyclist can easily move along.

(2)

Carefully adjust the cyclist along the arrows until the model runs smoothly:

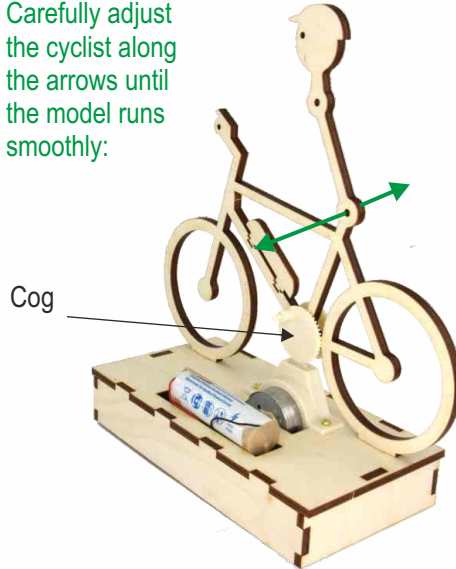

Allow the glue to dry approx. 10 minutes. Do not move the cyclist during this time.



Allow glue to dry for 10 minutes.

After 10 minutes you can remove the battery and install the solar cell as explained on page 10, however you can straight away glue the solar cell to the base.



4 ATTACHING THE CYCLIST'S ARMS AND LEGS



2 x

2 x **A**

17 x 2.5 mm

1 x **B**

18 x 2 mm

4 x



Spacer

(1) Insert 3 pins

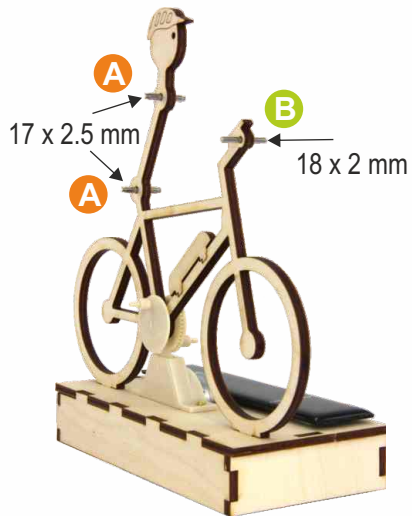

(2) Slide 4 wooden spacers onto the pins



(3) Attach arms



2 x  **A**

6 x  **B**

2 x 

2 x

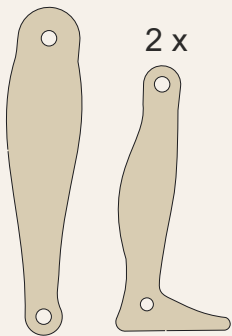

(4) Attach 4 caps, 2 large and 2 small.

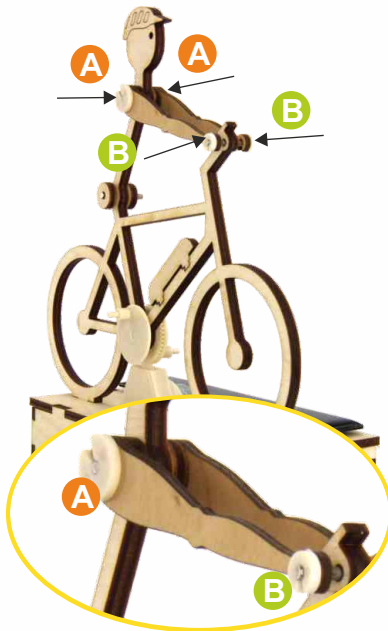

Attention: Position and attach parts exactly as shown:

Left leg: foot faces left, **right leg:** foot faces right

(5) Insert the pins in the two small **B** caps

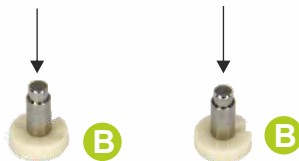

(6) Slide the thighs onto the small pins



Left leg

Right leg

(7) Slide the lower legs onto the pins, making sure the feet are facing in the correct direction.

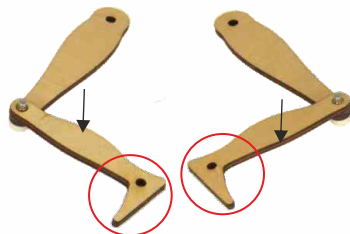

Left leg

Right leg

(8) Attach 2 small caps **B** onto the pin.

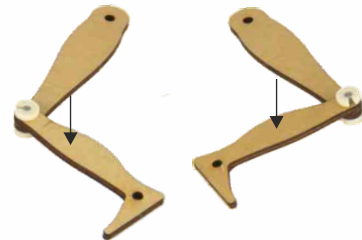

Left leg

Right leg

2 x **A**



2 x **B**



(9) Now attach the **right leg** to the right of the cyclist and the **left leg** to the left side. Slide the hole in each foot onto the pedal.

Extremely important:

Do not confuse the left and right leg or your cyclist will have knock knees!!

Right leg

Left leg



Attaching the right leg

Thigh position on the right leg: "inside", toward the cyclist, lower leg position: "outside", away from the cyclist:

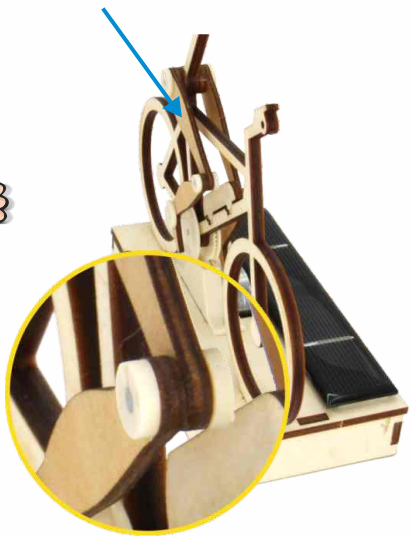

Attaching the left leg

Thigh position on the left leg: "inside", toward the cyclist, lower leg position: "outside", toward the solar cell:



(10) Now secure the pins with the caps. Only push the caps far enough onto the pedal so it does not crush the foot and still has a little play on the sides.

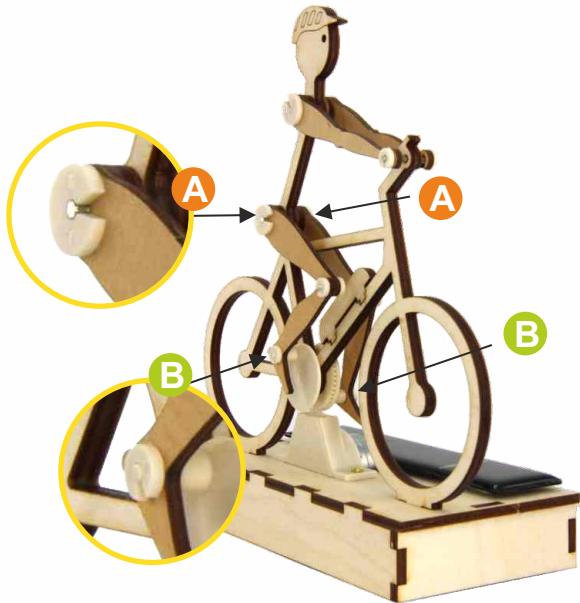

Congratulations - your cyclist is now ready to go, in sunlight or bright LED light!

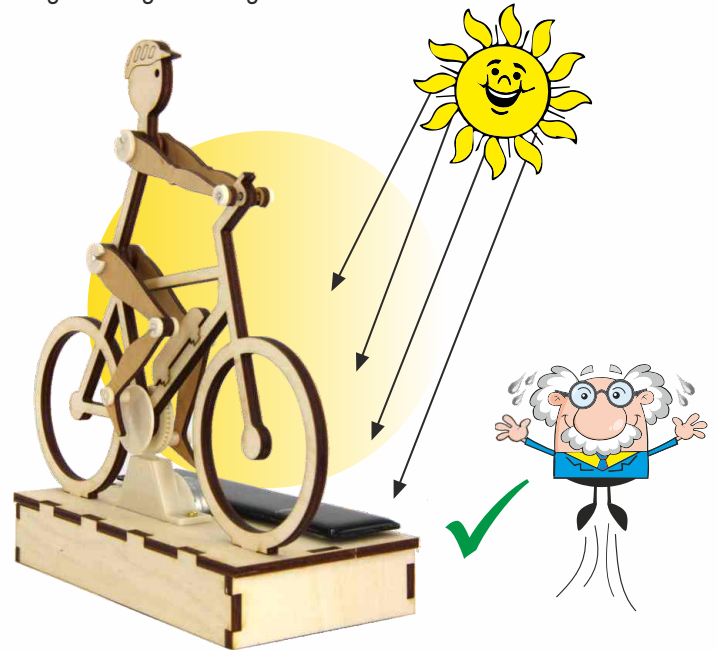

A solar module requires **sunlight** to generate maximum power. Without sunlight, it's like a wind turbine trying to generate power without wind.

REMEMBER!



Other great kits from *SOL-EXPERT* group:

TIP!

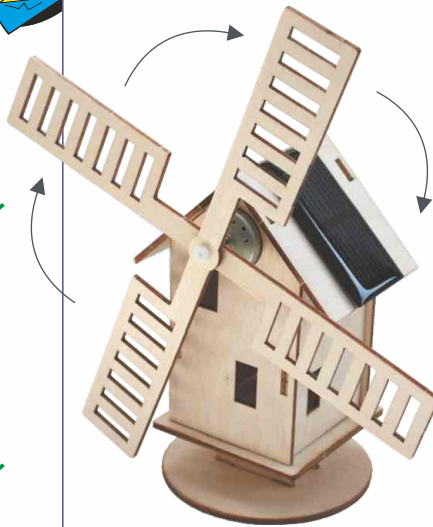
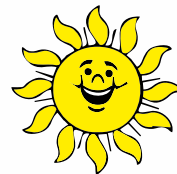
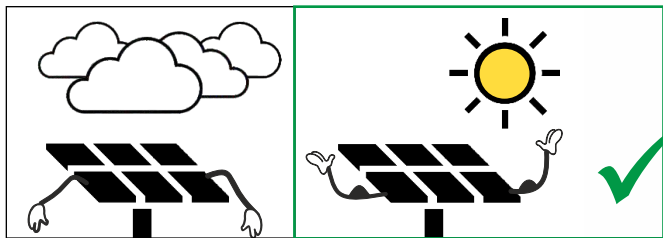
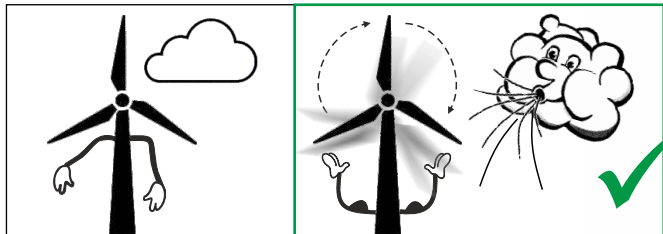

Solar Windmill "Holland"

If the solar module has good sun exposure, the blades on the windmill turn tirelessly.

The kit is quick and easy to assemble thanks to the detailed instructions with pictures.

Item no.: 40009

Other great kits from SOL-EXPERT group:

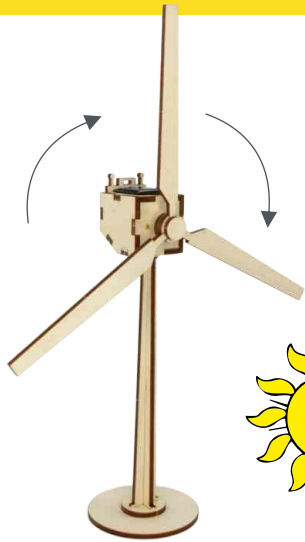

**Solar Wind Turbine "Sylt",
Wooden Building Kit**

The blades on the solar wind turbine "Sylt" start to turn quickly when the solar module has good sun exposure.
Item no.: 40105

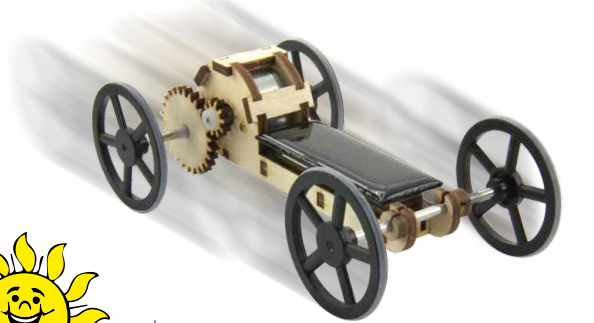

Solar Runner, Wooden Building Kit

Solar mobility made easy!
Running solar car as a kit! Quiet and solar-friendly – solar of course!
This 32-piece solar powered runner can be assembled without much experience thanks to the detailed instructions and the well-thought-out design.
Item no.: 40440



Solar House "Sunshine Villa"

Set the solar house in a sunny location and the solar cells charge the battery pack inside the house.
At dusk, a light automatically comes on inside the house and gives off a pretty amber light to shine through the windows.
Item no.: SOH

Hier geht es zur Anleitung:



<https://www.sol-expert-group.de/Solar-Produkte/Modelle-aus-Holz/Solar-Holz-Steckbausätze/Solar-Radler-E-Biker-Holzbausatz-zumSelberbauen::1349.html?language=de>

Click here for the instructions:



<https://www.sol-expert-group.de/Solar-products/Models-made-of-wood/Solar-wooden-building-kits/Solar-cyclist-e-biker-wooden-do-it-yourself-kit::1349.html?language=en>

Cliquez ici pour les instructions:



<https://www.sol-expert-group.de/Articles-solaires/Modeles-reduits-en-bois/Kits-dassemblage-solaires-en-bois/Cycliste-solaire-e-biker-kit-en-bois-pour-le-bricolage::1349.html?language=fr>

Klik hier voor de instructies:



<https://www.sol-expert-group.de/Producten-op-zonne-energie/Modellen-van-hout/In-elkaar-te-steken-houten-bouwsets-op-zonne-energie/Zonnefiets-e-biker-doe-het-zelf-houten-bouwpakket::1349.html?language=nl>

SOL-EXPERT kits keep you wanting more: detailed instructions, accurately fitting parts, high quality standard!

SOL-EXPERT group, C.Repy

Mehlisstrasse 19 - D-88255 Baidt

Tel.: +49 (0)7502 - 94115-0 - Fax: +49 (0)7502 - 94115-99

info@sol-expert-group.de - www.sol-expert-group.de

Find more cool kits at:

www.sol-expert-group.de

Save company address.



Please return electronic parts to a certified provider at the end of their useful life!

Changes and error reserved.

April 2021 / Christian Repky ©

MADE IN EUROPE

